

PHYSICS

1. For a simple pendulum, having time period T , the variation of kinetic energy (K.E.) with time (t) is represented by :

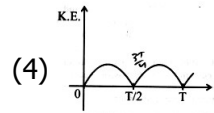
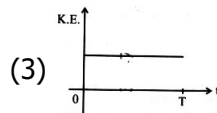
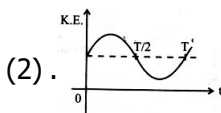
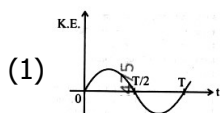

Ans. (4)

2. A room heater is rated 400 W, 220 V. If the supply voltage drops to 200 V, what will be the power consumed (approximately) ?

- (1) 400 W (2) 121 W (3) 331 W (4) 200 W

Ans. (3)

3. The angular speed of a flywheel is increased from 600 rpm to 1200 rpm in 10 s. The number of revolutions completed by the flywheel during this time is :

- (1) 600 (2) 300 (3) 900 (4) 150

Ans. (4)

4. The angular speed of a flywheel is increased from 600 rpm to 1200 rpm in 10 s. The number of revolutions completed by the flywheel during this time is :

- (1) 2.0 m/s (2) 0.2 m/s (3) 14.1 m/s (4) 1.41 m/s

Ans. (4)

5. A 100-turn closely wound circular coil of radius 5 cm has a magnetic field 3.14×10^{-3} T at its centre. The current flowing through the coil, and the magnitude of the magnetic moment of this coil are, respectively : (Take $\mu_0 = 4\pi \times 10^{-7}$ T m/A)

- (1) 2.5 A, 20 A m² (2) 2 A, 4 A m² (3) 2.5 A, 2 A m² (4) 2 A, 10 A m²

Ans. (3)

6. A submarine is designed to withstand an absolute pressure of 100 atm. How deep can it go below the water surface ?

(Consider the density of water = 1000 kg m⁻³, 1 atm = 1 × 10⁵ Pa and gravitational acceleration $g = 10$ m/s²)

- (1) 9900 m (2) 990 m (3) 9000 m (4) 99 m

Ans. (2)

7. Match List I with List II :

List I

- A. $E = h\nu$
B. Diffraction and Interference
C. $\lambda = h/p$
D. Compton effect

List II

- I. de Broglie wavelength
II. Particle nature of light
III. Wave nature of light
IV. Energy of photon

Choose the correct answer from the options given below :

- (1) A-IV, B-III, C-II, D-I (2) A-IV, B-III, C-I, D-II (3) A-I, B-IV, C-III, D-II (4) A-IV, B-I, C-II, D-III

Ans. (2)

8. Match List I with List II :

List I

A. Young's Modulus

B. Compressibility

C. Bulk Modulus

D. Poisson's Ratio

List II

I. $\frac{\Delta d}{\Delta L} \left(\frac{L}{d} \right)$

II. $\frac{FL}{A(\Delta L)}$

III. $-\frac{1}{\Delta P} \left(\frac{\Delta V}{V} \right)$

IV. $-P \left(\frac{V}{\Delta V} \right)$

Choose the correct answer from the options given below :

(1) A-III, B-II, C-I, D-IV (2) A-II, B-III, C-IV, D-I (3) A-I, B-IV, C-III, D-II (4) A-IV, B-I, C-II, D-III

Ans. (2)

9. Five capacitors of capacitances $C_1 = C_2 = C_3 = C_4 = 10 \mu\text{F}$ and $C_5 = 2.5 \mu\text{F}$ are connected as shown, along with a battery of 50 V.

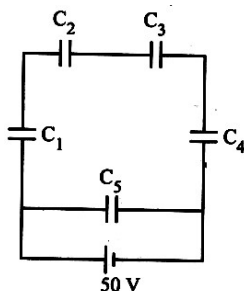

The equivalent capacitance and the charges on each capacitor respectively are :

(1) $4 \mu\text{F}$, $250 \mu\text{C}$ on C_1 to C_4 and $125 \mu\text{C}$ on C_5 (2) $5 \mu\text{F}$, $250 \mu\text{C}$ on all capacitors
(3) $5 \mu\text{F}$, $125 \mu\text{C}$ on C_1 to C_4 and $25 \mu\text{C}$ on C_5 (4) $5 \mu\text{F}$, $125 \mu\text{C}$ on all capacitors

Ans. (4)

10. The amount of work done to raise a mass 'm' from the surface of the Earth to a height equal to the radius of the Earth 'R', will be :

(1) $mg \frac{R}{2}$ (2) $mg R$ (3) $mg \frac{R}{4}$ (4) $2 mg R$

Ans. (1)

11. When a ruler falls vertically, 5 different persons catch it with different reaction times. ($g = 9.8 \text{ m s}^{-2}$)

A. Person A has reaction time of 0.20 s. B. Person B has reaction time of 0.22 s.
C. Person C has reaction time of 0.18 s. D. Person D has reaction time of 0.19 s.
E. Person E has reaction time of 0.21 s.

What is the correct order of the distance travelled by the ruler for each person ?

(1) $B > E > A > C > D$ (2) $C > D > A > E > B$ (3) $C > D > A > B > E$ (4) $B > E > A > D > C$

Ans. (4)

12. The power of a crane, which lifts a mass of 1000 kg to a height of 20 m in 10 s is : ($g = 9.8 \text{ m/s}^2$)
 (1) 19.6 kW (2) 19.6 W (3) 39.2 kW (4) 39.2 W

Ans. (1)

13. Consider two uncharged capacitors of equal capacitance 200 pF. One of them is charged by a 100 V supply and disconnected. Now this capacitor is connected to the uncharged capacitor. The amount of electrostatic energy lost in the process is :

- (1) 0.5 J (2) 1.0×10^{-6} J (3) 0.5×10^{-6} J (4) 1.0 J

Ans. (3)

14. An ac circuit contains a resistance of 1 k Ω , a capacitor of 0.1 μF and an inductor of 1 mH connected in series. The resonance frequency of the circuit is approximately :

- (1) 15.9 kHz (2) 20.7 kHz (3) 10.1 kHz (4) 13.5 kHz

Ans. (1)

15. The figure given below shows a long straight solid wire of circular cross-section of radius 'a' carrying steady current I. The current I is uniformly distributed across its cross-section. The plot which correctly represents the variation of magnetic field (B) with distance (r) from the axis of the conductor in the region is :

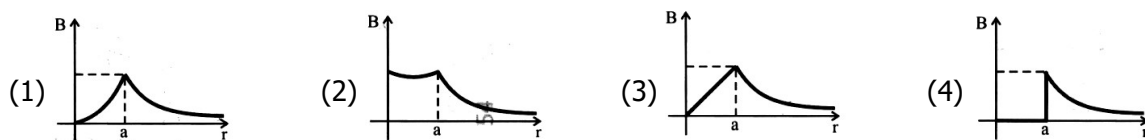

Ans. (3)

16. An electric heater supplies heat to a system at a rate of 100 W. If the system performs work at a rate of 75 J/s, then the rate at which internal energy increases will be :

- (1) 75 W (2) 25 W (3) 100 W (4) 125 W

Ans. (2)

17. The peak value of an alternating current is 5 A and frequency is 60 Hz. How long will the current, starting from zero, take to reach the peak value ?

- (1) $\frac{1}{120}$ s (2) $\frac{1}{240}$ s (3) $\frac{1}{30}$ s (4) $\frac{1}{60}$ s

Ans. (2)

18. In Young's double slit experiment, using monochromatic light of wavelength λ , the intensity of light at a point on the screen where the path difference is λ , is K units. The intensity of light at a point where the path difference is $\frac{\lambda}{3}$ will be :

- (1) K (2) 2 K (3) $\frac{K}{3}$ (4) $\frac{K}{4}$

Ans. (4)

19. Four statements are given (A is mass number) :

- A. The volume of a nucleus is proportional to $A^{1/3}$.
B. The volume of a nucleus is proportional to A.
C. The difference in mass of an atom and its nucleus is called the mass defect.
D. The difference in mass of a nucleus and its constituents is called the mass defect.

Choose the correct answer from the options given below :

- (1) A and D are true, but B and C are false (2) B and D are true, but A and C are false
(3) B and C are true, but A and D are false (4) A and C are true, but B and D are false

Ans. (2)

20. In interference and diffraction, the light energy is redistributed. If it reduces in one region, producing a dark fringe, it increases in another region, producing a bright fringe.

- A. As there is no gain or loss of energy, these phenomena are consistent with the principle of conservation of energy.
B. Diffraction and interference are characteristics exhibited only by light waves.

Choose the correct answer from the options given below :

- (1) A is false, but B is true (2) A is true, but B is false
(3) A is true and B is also true (4) Both A and B are false

Ans. (2)

21. A resistor is connected to a battery of 12 V emf and internal resistance 2Ω . If the current in the circuit is 0.6 A, the terminal voltage of the battery is :

- (1) 12 V (2) 1.2 V (3) 10 V (4) 10.8 V

Ans. (4)

22. In a metre bridge experiment (see figure), the positions of the cell, E, and galvanometer, G, are interchanged. We galvanometer :

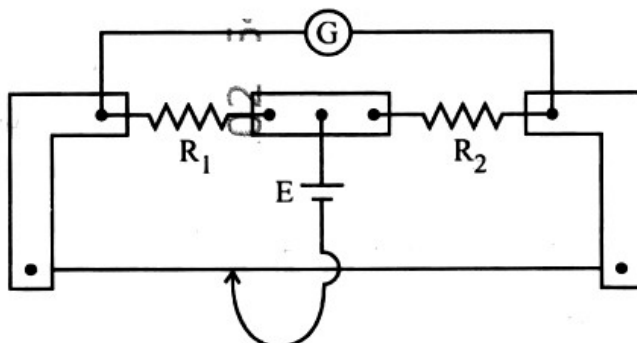

- (1) Only the right-sided deflection
 (2) Only the left-sided deflection
 (3) There will be no deflection irrespective of the position of the jockey
 (4) Both right-sided and left-sided deflection and at balance point, no deflection

Ans. (4)

23. Savitha, a XI standard student, while conducting an experiment to determine the effective length of a simple pendulum L, notes down the data of time taken to complete 30 oscillations as 60 s and hence calculates the length of the simple pendulum as : (Take $K = 9.8$, and $g = 9.8 \text{ m/s}^2$)

- (1) 0.75 m (2) 1 m (3) 1.5 m (4) 2 m

Ans. (2)

24. Which of the following statements are correct ?

- A. Inside a conductor, the electrostatic field is zero.
 B. Electric field at the surface of a charged conductor does not depend on its surface charge density.
 C. The interior of a charged conductor can have no excess charge in the static situation.
 D. At the surface of a charged conductor, the electrostatic field must be normal to the surface at every point.
 E. The electrostatic potential is zero everywhere inside a charged conductor.

Choose the correct answer from the options given below :

- (1) A, C and D only (2) A, C and E only (3) C, D and E only (4) A, B and D only

Ans. (1)

25. Two statements are given below :

- A. When the forward bias voltage across a p-n junction diode increases above a certain threshold voltage, the diode current increases significantly.
 B. This current is called reverse saturation current.

Choose the correct answer from the options given below :

- (1) Both Statements A and B are true (2) Both Statements A and B are false
 (3) Statement A is true, but Statement B is false (4) Statement A is false, but Statement B is true

Ans. (3)

26. In a concave lens, a ray of light emanating from the object parallel to the principal axis of the lens, after refraction :
- (1) passes through the second principal focus.
 - (2) appears to diverge from the first principal focus.
 - (3) passes through $2F$, which is the radius of curvature of the lens.
 - (4) emerges parallel to the principal axis.

Ans. (2)

27. An unknown nucleus has a nuclear density of $2.29 \times 10^{17} \text{ kg/m}^3$ and mass of $19.926 \times 10^{-27} \text{ kg}$. Its mass number A is approximately : (Take $R_0 = 1.2 \times 10^{-15} \text{ m}$, $4\pi = 12.56$)

- (1) 16 (2) 20 (3) 12 (4) 19

Ans. (3)

28. A galvanometer of resistance 100Ω gives full scale deflection for a current of 1 mA . It is converted into an ammeter of range $0 - 10 \text{ A}$. The shunt required is :

- (1) 0.001Ω (2) 0.10Ω (3) 1.0Ω (4) 0.01Ω

Ans. (4)

29. A thin wire of length ' L ' and linear mass density ' m ' is bent into a circular ring (in x - y plane) with centre ' C ' as shown in figure. The moment of inertia of the ring about an axis yy' will be :

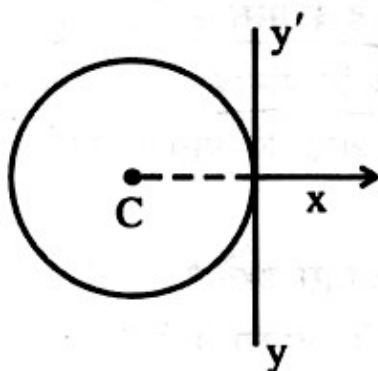

- (1) $\frac{3mL^3}{8\pi}$ (2) $\frac{3mL^2}{8\pi^2}$ (3) $\frac{3mL^3}{8\pi^2}$ (4) $\frac{3mL^2}{8\pi}$

Ans. (3)

30. For a travelling harmonic wave $y(x, t) = 2.0 \cos 2\pi(10 t - 0.0080 x + 0.35)$, where x and y are in cm and t in s. The phase difference between oscillatory motion of two points separated by a distance of 0.5 m is :

- (1) $0.08 \pi \text{ rad}$ (2) $0.008 \pi \text{ rad}$ (3) $0.8 \pi \text{ rad}$ (4) $8 \pi \text{ rad}$

Ans. (3)

31. A box of mass 15 kg is kept on the floor of a stationary trolley. The coefficient of static friction between the box and the trolley is 0.12 . Keeping the box in stationary state over the trolley, the maximum acceleration with which the trolley can be moved horizontally in m s^{-2} is : ($g = 10 \text{ m/s}^2$)

- (1) 1.8 (2) 1.2 (3) 1.5 (4) 2.1

Ans. (2)

32. In the circuit shown below, the voltage appearing across the diode D will be of the form :

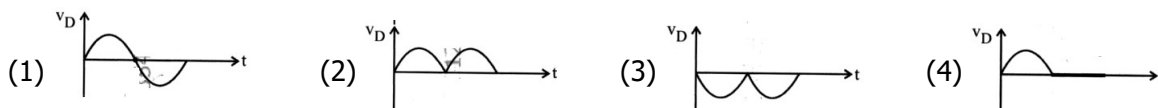
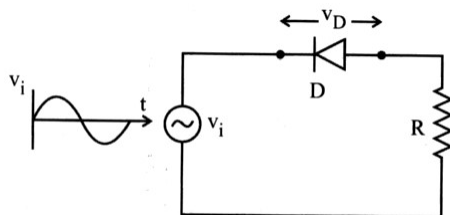

Ans. (4)

33. A flask contains argon and chlorine in the ratio of 2 : 1 by mass. The temperature of the mixture is 27°C.

The ratio of root mean square speed of the molecules of the two gases $\left(\frac{v_{rms}^{Ar}}{v_{rms}^{Cl}}\right)$ is :

(Atomic mass of argon = 40.0 u and molecular mass of chlorine = 70.0 u)

- (1) $\frac{7}{4}$ (2) $\frac{2}{\sqrt{7}}$ (3) $\frac{\sqrt{7}}{2}$ (4) $\frac{7}{2}$

Ans. (3)

34. Match List I with List II :

List I

(Electromagnetic wave)

- A. Microwave
B. Visible light
C. Gamma rays
D. Infra-red rays

List II

(Production)

- I. Electrons in atoms emit light when they move from a higher energy level to a lower energy level
II. Radioactive decay of nucleus
III. Vibration of atoms and molecules
IV. Klystron valve or magnetron valve

Choose the correct answer from the options given below :

- (1) A-IV, B-III, C-II, D-I (2) A-III, B-IV, C-I, D-II (3) A-III, B-I, C-II, D-IV (4) A-IV, B-I, C-II, D-III

Ans. (4)

35. The magnitude and direction of the acceleration produced in a body of mass 5 kg when two mutually perpendicular forces 8 N and 6 N act on it, are respectively :

- (1) 2 m s^{-2} ; $\tan^{-1} (3/4)$ with 8 N force (2) 2 ms^{-2} ; $\tan^{-1} (4/3)$ with 8 N force
(3) 2 m s^{-2} ; $\tan^{-1} (3/4)$ with 6 N force (4) 20 m s^{-2} ; $\tan^{-1} (4/3)$ with 8 N force

Ans. (1)

36. The current I in the circuit shown below is : (All diodes are ideal and identical)

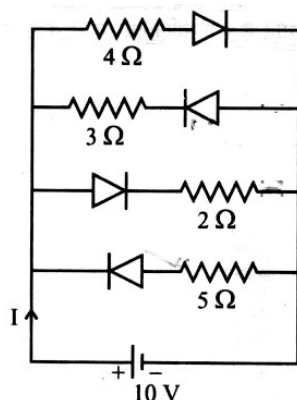

- (1) $\frac{1}{3}$ A (2) $\frac{15}{2}$ (3) $\frac{5}{3}$ A (4) $\frac{5}{9}$ A

Ans. (2)

37. For a metal of work function 6.6 eV, which of the following wavelengths of incident radiation does not give rise to the photoelectric effect ? (Take Planck's constant as 6.6×10^{-34} J s)

- (1) 200 nm (2) 100 nm (3) 50 nm (4) 150 nm

Ans. (1)

38. The speed of light in vacuum is taken as unity. If light takes 6 min 40 s to reach the Earth from the Sun, the distance between the Sun and the Earth in new unit is :

- (1) 3×10^8 (2) 500 (3) 3×10^{10} (4) 400

Ans. (4)

39. A rectangular wire loop of sides 8 cm and 3 cm with a small cut, is moving out of a region of uniform magnetic field of magnitude 0.3 T directed normal to the plane of the loop. The emf developed across the cut, if the velocity of the loop is 2 cm s^{-1} , in a direction normal to the shorter side of the loop, will be:

- (1) 1.8×10^{-4} volt (2) 1.3×10^{-4} volt (3) 1.2×10^{-4} volt (4) 4.8×10^{-4} volt

Ans. (1)

40. The following plots show variation of velocity (v) with time (t), of a ball thrown vertically upward, and falling back. Which of the following plots is/are correct :

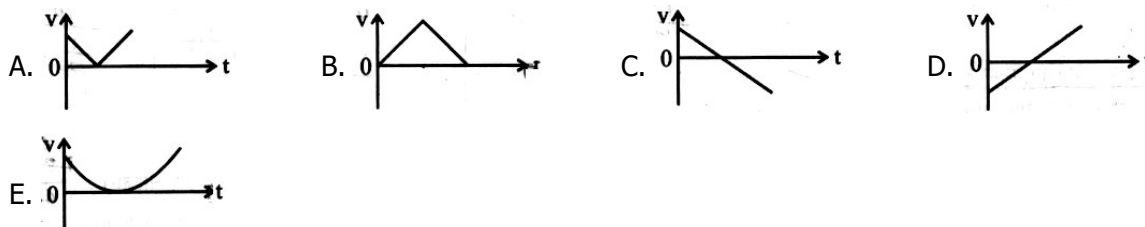

- (1) B only (2) A and E only (3) C only (4) D only

Ans. (3*, 4)

41. In a vernier callipers, 20 VSD coincide with 16 MSD (each division of length 1 mm). The least count of the vernier callipers is :

- (1) 0.2 cm (2) 0.1 cm (3) 0.02 cm (4) 0.01 cm

Ans. (3)

42. Each side of a metallic cube of mass 5.580 kg is measured to be 9.0 cm. Keeping the significant figures in view, the density of the material of the cube can be best expressed as $X \times 10^3 \text{ kg m}^{-3}$, where the value of X is :

- (1) 7.654 (2) 7.7 (3) 7.65 (4) 7.6

Ans. (4)

43. A ray of monochromatic light is passing through an equilateral prism (ABC) as shown in the figure. The refracted ray (QR) is parallel to its base (BC) and the angle of incidence (i) is 50° . Then the angle of deviation (δ) is :

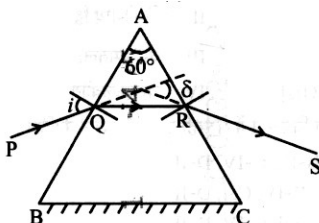

- (1) 45° (2) 55° (3) 35° (4) 40°

Ans. (4)

44. In the first excited state of hydrogen atom, the energy of its electron is -3.4 eV . The radial distance of the electron from the hydrogen nucleus in this case is approximately :

(Take $1 \text{ eV} = 1.6 \times 10^{-19} \text{ J}$, $e = 1.6 \times 10^{-19} \text{ C}$ and $\frac{1}{4\pi\epsilon_0} = 9 \times 10^9 \text{ Nm}^2 / \text{C}^2$)

- (1) $2.1 \times 10^{-8} \text{ m}$ (2) $2.1 \times 10^{-10} \text{ m}$ (3) $2.1 \times 10^{-11} \text{ m}$ (4) $2.1 \times 10^{-9} \text{ m}$

Ans. (2)

45. A uniform metallic wire having resistance 4Ω is bent to form a square loop (ABCD) (see figure). A resistance of 2Ω is connected between points B and D and a battery of 2 V is connected across points A and C as shown in the figure. Now the value of current (I) is :

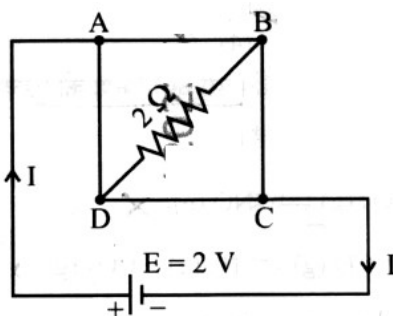

- (1) 4 A (2) 4.5 A (3) 8 A (4) 2 A

Ans. (4)